

PARTS LIST

ITEM	QTY	PART NO.	PART DESCRIPTION
1	1	SCX4	3/8" x 7" x 8-3/4" CROSSOVER PLATE
2	2	GUB-4352	1/2" x 3" x 5-1/4" GALV U-BOLT KIT
3	2	GUB-4355	1/2" x 3-5/8" x 5" GALV U-BOLT KIT

U-BOLT KIT INCLUDES:
 (1) GALVANIZED U-BOLT
 (2) GALVANIZED LOCK WASHERS
 (2) GALVANIZED FLAT WASHERS
 (2) GALVANIZED NUTS

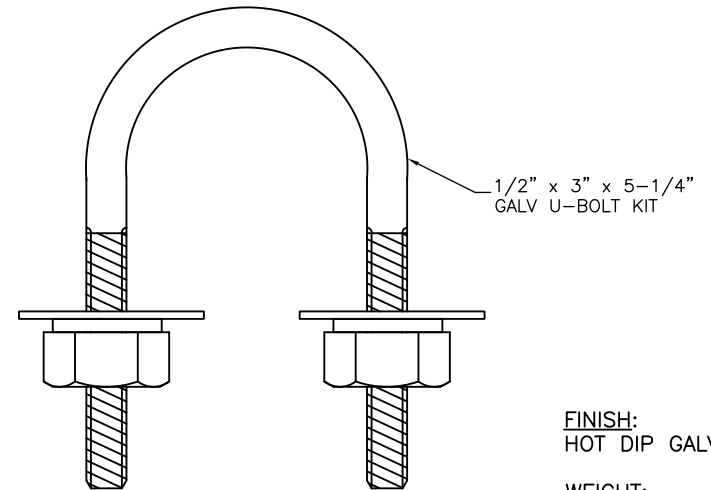
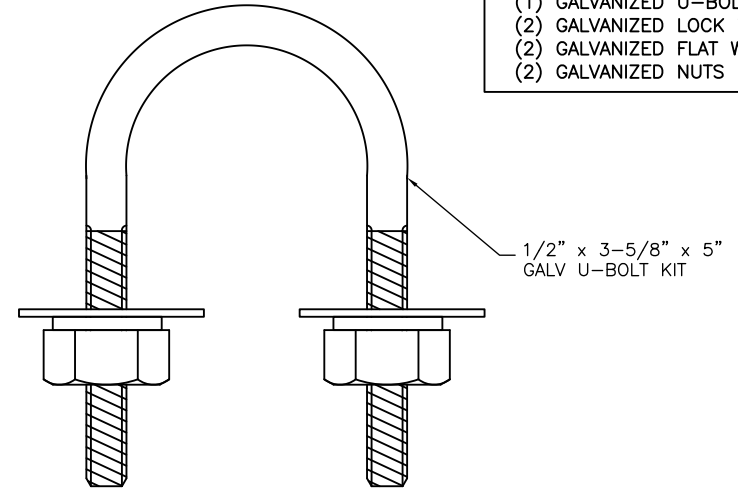
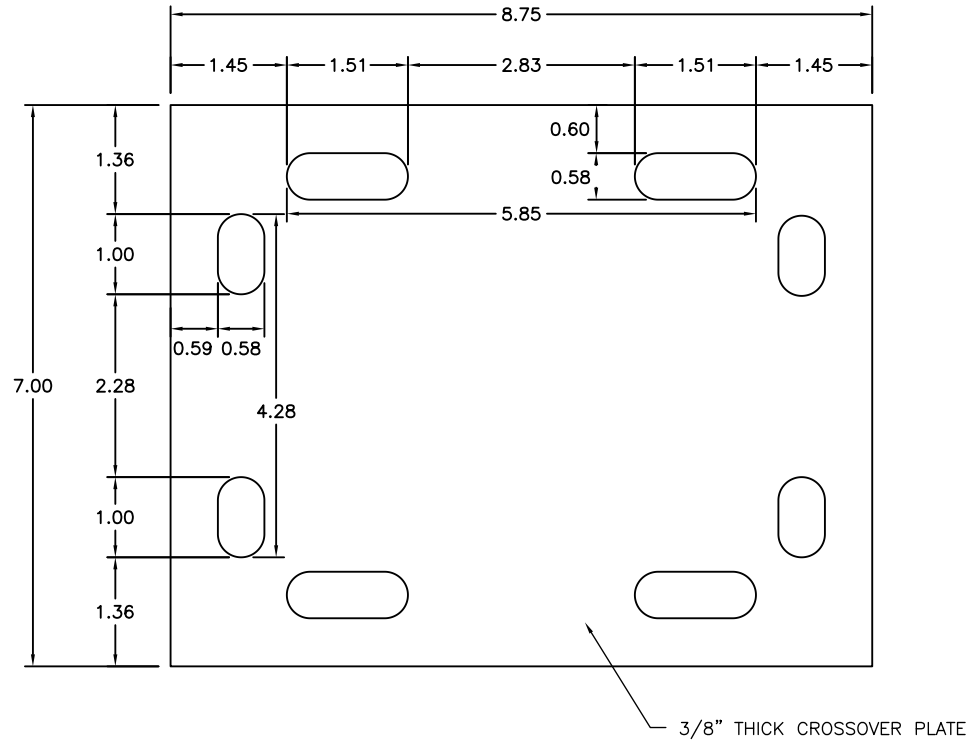

FINISH:
HOT DIP GALVANIZED

WEIGHT:
8.5LBS.

TOLERANCE UNITS

TOLERANCES ON DIMENSIONS, UNLESS OTHERWISE NOTED ARE:
 SAWED, SHEARED AND GAS CUT EDGES ($\pm .030"$)
 DRILLED AND GAS CUT HOLES ($\pm .030"$)—NO CONING OF HOLES
 LASER CUT EDGES AND HOLES ($\pm .010"$)
 BENDS ARE $\pm 1/2$ DEGREE
 ALL OTHER MACHINING ($\pm .030"$)
 ALL OTHER ASSEMBLY ($\pm .060"$)

PROPRIETARY NOTE:

THE DATA AND TECHNIQUES CONTAINED IN THIS DRAWING ARE PROPRIETARY INFORMATION OF IZZY INDUSTRIES AND CONSIDERED TRADE SECRET. ANY USE OR DISCLOSURE WITHOUT THE CONSENT OF IZZY INDUSTRIES IS STRICTLY PROHIBITED.

PART NO.		CP-2530	
DESCRIPTION			
CROSSOVER PLATE 2-7/8" O.D. TO 3-1/2" O.D.			
DRAWN BY:		REVISION:	
NMB		1	
CHECKED BY:	701 Riverwood Drive Pembroke, NH 03275	SCALE:	
		-	
DATE:		SHEET:	
09.21.17		1 OF 1	