

PARTS LIST						
ITEM	QTY	PART NO.	PART DESCRIPTION	LENGTH	UNIT WT.	NET WT.
1	1	V-1.5-6	4" V-CLAMP	6"	0.91	0.91

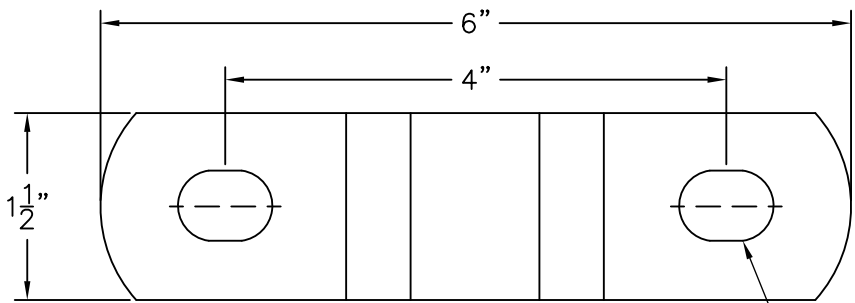
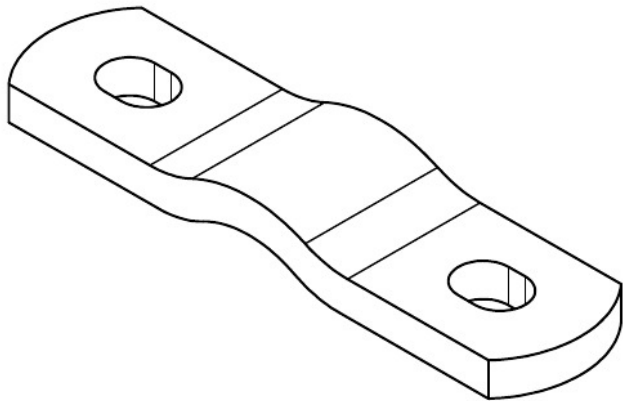
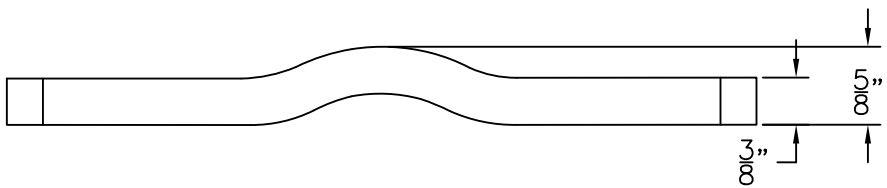

9/16" ϕ x 3/4" SLOT
(2 PLACES)

FINISH:
HOT DIP GALVANIZED

TOLERANCE UNITS
 TOLERANCES ON DIMENSIONS, UNLESS OTHERWISE NOTED ARE:
 SAWED, SHEARED AND GAS CUT EDGES ($\pm .030"$)
 DRILLED AND GAS CUT HOLES ($\pm .030"$)—NO CONING OF HOLES
 LASER CUT EDGES AND HOLES ($\pm .010"$)
 BENDS ARE $\pm 1/2$ DEGREE
 ALL OTHER MACHINING ($\pm .030"$)
 ALL OTHER ASSEMBLY ($\pm .060"$)

PROPRIETARY NOTE:
 THE DATA AND TECHNIQUES CONTAINED IN THIS DRAWING ARE PROPRIETARY INFORMATION OF IZZY INDUSTRIES AND CONSIDERED TRADE SECRET. ANY USE OR DISCLOSURE WITHOUT THE CONSENT IF IZZY INDUSTRIES IS STRICTLY PROHIBITED.

PART NO.		V-1.5-6	
DESCRIPTION		4" V-CLAMP	
DRAWN BY:		REVISION:	
NMB		—	
CHECKED BY:	701 Riverwood Drive Pembroke, NH 03275 925.344.5970	SCALE:	
DATE:		—	
02.18.15		SHEET:	
		1 OF 1	